



INTELLIGENT HEATING SOLUTIONS

INSTRUCTION MANUAL

LOKI

12 Milner Str, Paarden Eiland, 7405 Cape Town, South Africa
www.hydrofire.co.za



Introducing the Loki Instruction Manual - Your Guide to Optimal Performance and Safety

Thank you for choosing our Loki Pellet Heater. This instruction manual has been carefully crafted to provide you with all the necessary information for the installation, operation, and maintenance of your Pellet Heater. We understand the importance of a clear and concise manual, and we aim to deliver just that.

Contents

1. Introduction:	4
2. Instruction Manual Preservation:	4
3. Warranty Information:	4
4. Technical Specification:	5
5. Technical Parameter:	6
5.1 Internal Sectional Drawings:	6
5.2 Interface Introduction:	7
5.2.1 Description:	7
6. Functions and Operation Procedures:	8
6.1 Start:	8
6.2 Turning off:	8
6.3 Menu:	9
6.3.1 Press , screen as blow:	9
6.4 Temperature set:	12
6.4.1 Set room temperature:	12
6.4.2 Set fire power level:	12
6.4.3 Set convection motor speed:	13
6.5 PARAMETERS SET:	13
6.6 Overload fuse:	14
7 Operating instruction of remote controller:	14
8 Installation of Stove:	15
8.1 Assembly of Flue pipe:	15

- 8.2 Floor Protection: 16
- 8.3 Surrounding Safe Distance: 17
- 8.4 Power Supply: 18
- 8.5 Oxygen Supply for Combustor: 18
- 9 General Steps and Instructions for operation: 18
 - 9.1 General Notes: 18
 - 9.2 Control Unit: 18
 - 9.3 Ignition Solution in case of auto-ignition failed: 18
- 10 Cleaning and Maintenance..... 16
 - 10.1 General:..... 16
 - 10.2 Ash cleanup: 10.2.1 10.2.1 Cleaning of Burner: 16
 - 10.2.2 Cleaning of burner pot base:..... 16
 - 10.2.3 Cleaning of ash box:..... 17
 - 10.3 Cleaning of the flue inside the fireplace..... 17
 - 10.3.1 The operation steps are performed as follows: 18
 - 10.4 Clean up the smoke exhaust fan: 18
 - 10.4.1 Cleaning of smoke pipes: 19
 - 10.5 Door Glass Cleaning:..... 19
 - 10.6 Hopper Cleaning: 19
 - 10.7 Seal check 20
- 11. Faults - Causes – Solution 20
 - 11.1 Errors and Solutions:..... 20
 - 11.2 Causes and solutions for faults: 24
- 12. Wiring Diagram: 27

1. Introduction:

Dear Valued Customer,

We would like to express our gratitude for choosing our Loki Pellet Heater. This manual has been designed to ensure that you have a seamless experience with our Pellet Heater. Please take the time to read through this manual thoroughly to familiarize yourself with the necessary information for optimal performance.

2. Instruction Manual Preservation:

We highly recommend keeping this manual in a safe and easily accessible location, even in the event of ownership or location changes. Should you require additional copies, please do not hesitate to contact Hydrofire.

3. Warranty Information:

To validate and sustain the integrity of your limited warranty, it is imperative that all installation guidelines, chimney sizing specifications, and clearance profiles outlined within this document are strictly followed. All physical installation procedures must be executed by a qualified solid-fuel appliance installer in accordance with local building regulations and applicable SANS codes.

As the authorized distributor, we undertake to process and facilitate the remedy of any verified structural or material defect within a maximum period of 45 days from the receipt of formal written notification. Please note that components in direct, continuous contact with high-temperature fire—including thermal glass panes, fire grates, and high-density mechanical rope gaskets—constitute standard wear-and-tear items and are excluded from the core coverage.

CORE WARRANTY MANDATES:

1. Warranty is 2 years.
2. Visual inspection and chimney sweep every 1-2 years.
3. Any build-up on the surface of the boiler should be scraped off.

Machines that fail due to unauthorized modification, or usage of poor quality fuel non-compliant with European DIN plus standard metrics compromise the product and will render the warranty null and void.

4. Technical Specification:

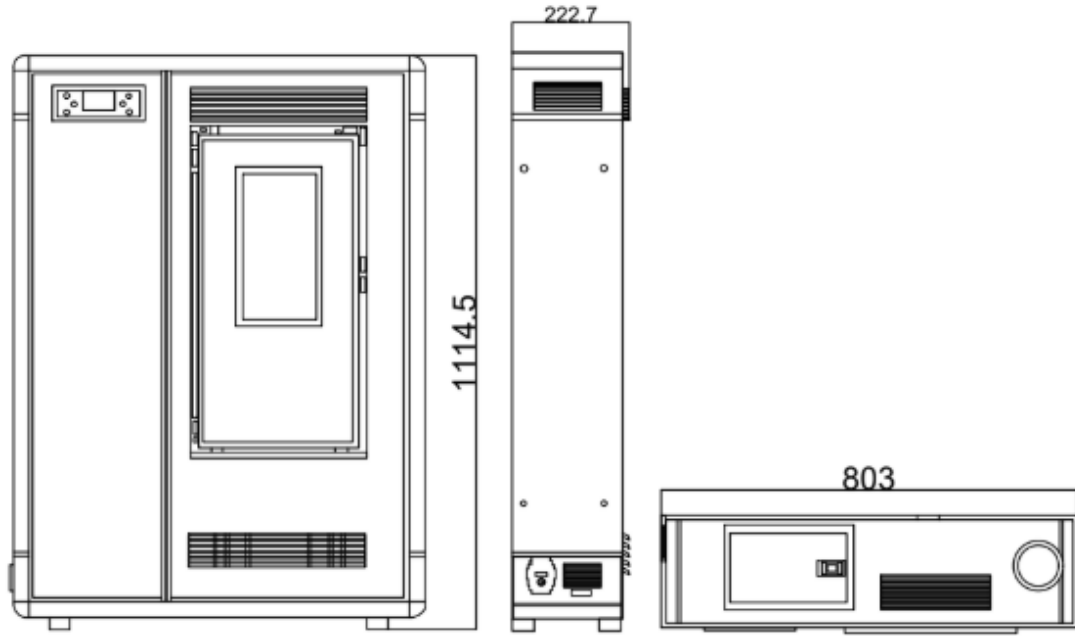

Engineering Parameters & Operational Metrics	
Height*Width*Depth	1120 x 820 x 250mm
Nominal heat output	8 KW (5 – 10 KW)
Material	Steel
Weight	80 KG
Efficiency	84%
Room heating capacity	50m ² – 90m ²
Flue outlet	Rear
Flue pipe outlet	80mm

Loki

Free Standing Wood Pellet Heater

5. Technical Parameter:

5.1 Internal Sectional Drawings:

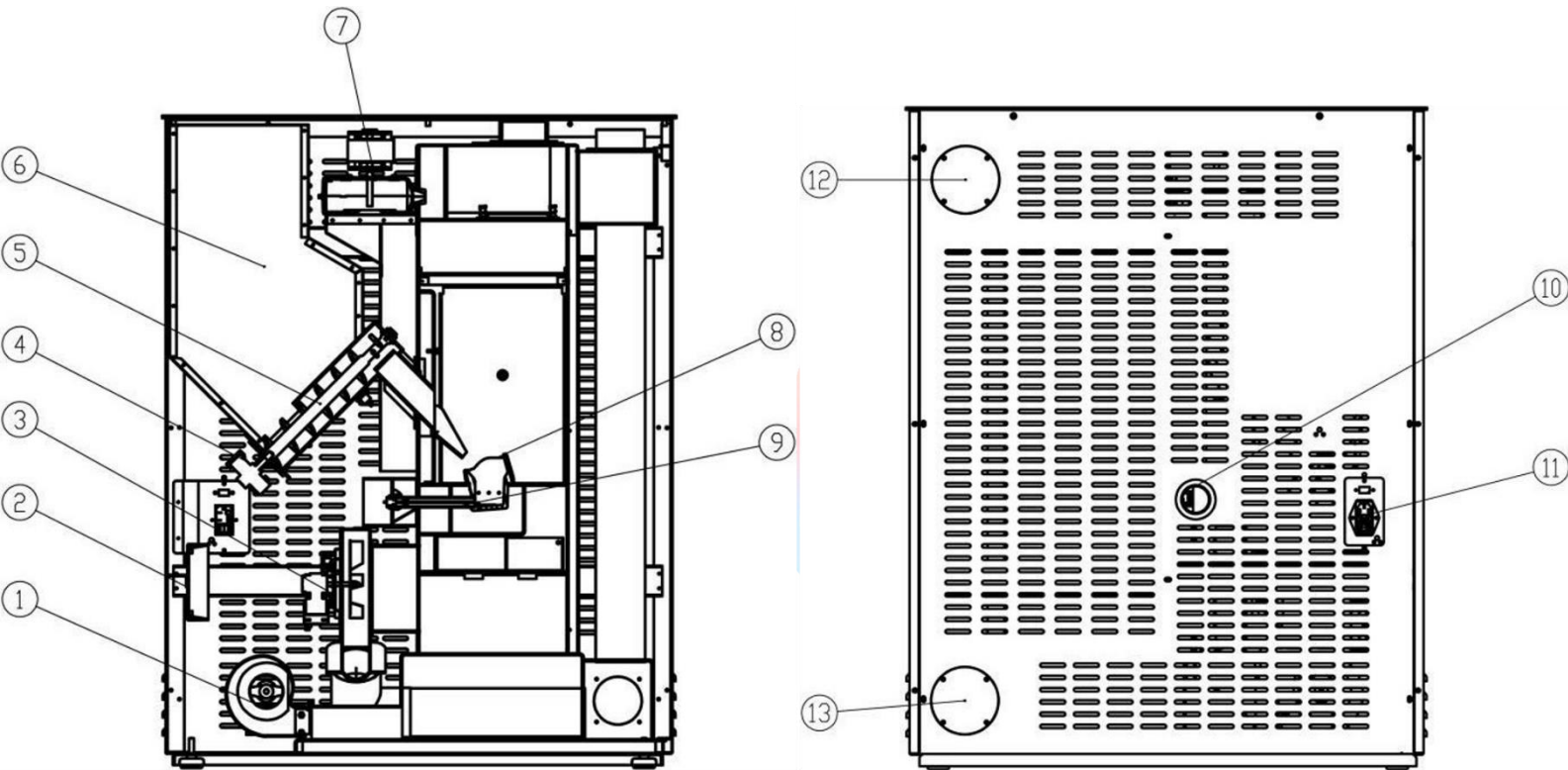





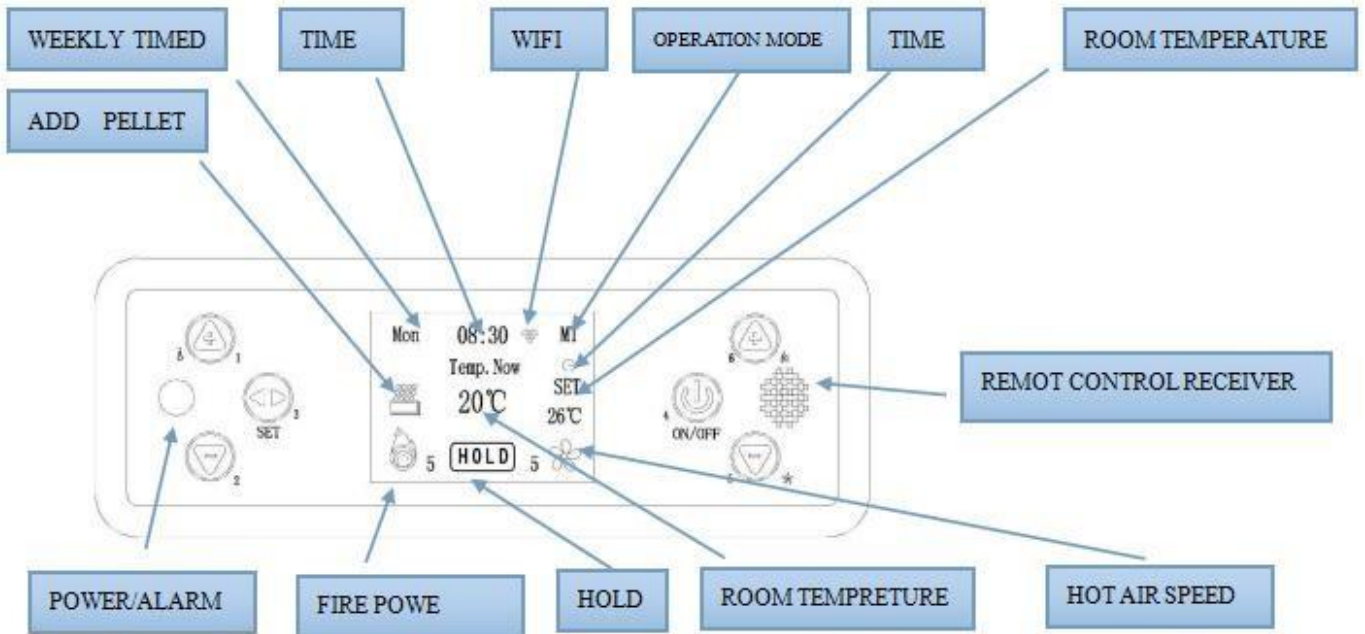



1. Primary heater	2. Main board
3. Exhaust motor	4. feeder motor
5. feeding roller	6. Hopper
7. Secondary heater	8. exhaust gas
9. ignitor	10. Air intake
11. Three-in-one switc	12. Primary Smoke vents
13. Secondary Smoke vents	

5.2 Interface Introduction:



5.2.1 Description:

- 4  ON/OFF button; press  for 3 seconds to start or to stop the stove; short to cancel or return.
- 3  Set key; press  to enter the setting menu, set the current time, combustion mode, timed ON/OFF.
- 1  Set room temperature key/Plus key.
- 2  Set room temperature key/Minus key.
While stove in operation, press this key to check the smoke temperature.
- 6  Set fire power key, press this key to enter mode of setting fire power, weak to strong, F1 TO F5, press "+" or "-" to adjust.
- 5  Set hot air speed key, press this key to enter mode of wind power set, weak to strong, S1-S3, press "+" or "-" to adjust.

6. Functions and Operation Procedures:

6.1 Start:

Note: Burning pot must be checked and remove all the ash in it before starting.

Plug in power supply → power light lights up → long press  for 3 seconds → the screen lights and displays “ON” stove begins igniting.

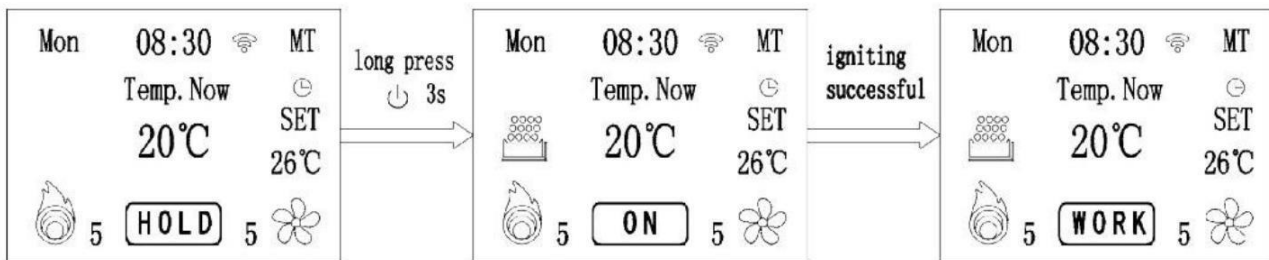

Note: First time use of new stove, there will be a little smoke and pungent smell, it is caused by heating the paint and slushing oil on plate, please open the window, after a short while of combustion it will disappear.

6.2 Turning off:



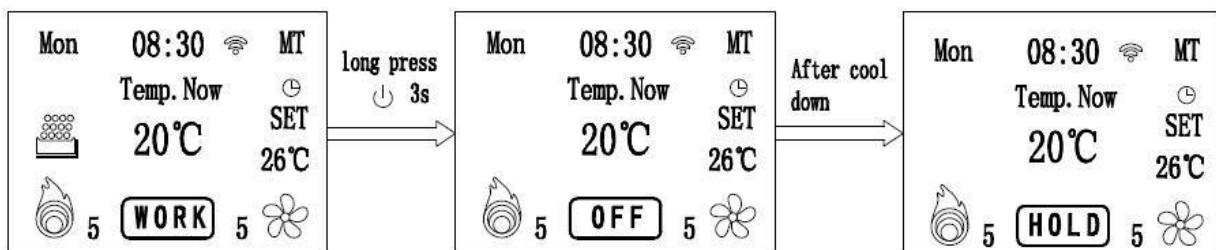

Long press  for 3 seconds → the screen displays “TURNING OFF”, means that the stove enters into turning off phase, auger motor stops loading pellet, exhaust motor and convection motor continue working until the stove gets cool and smoke temperature gets lower than 50°C, then the stove enters into OFF mode.

The screen appears as follows:



6.3 Menu:

6.3.1 Press  screen as blow:

When stove is working, press  key, appears successively the menu of LANGUAGE, TIME, MODE, WEEKLY, GEN TECHNICAL, DEEP. TECHNICAL, LCD LIGHT, SELF CHECK, FACTORY SET, INFORMATION. WIFI. (As the above pic). Press   to scroll it, then press  it enters into the interface of the menu chosen.

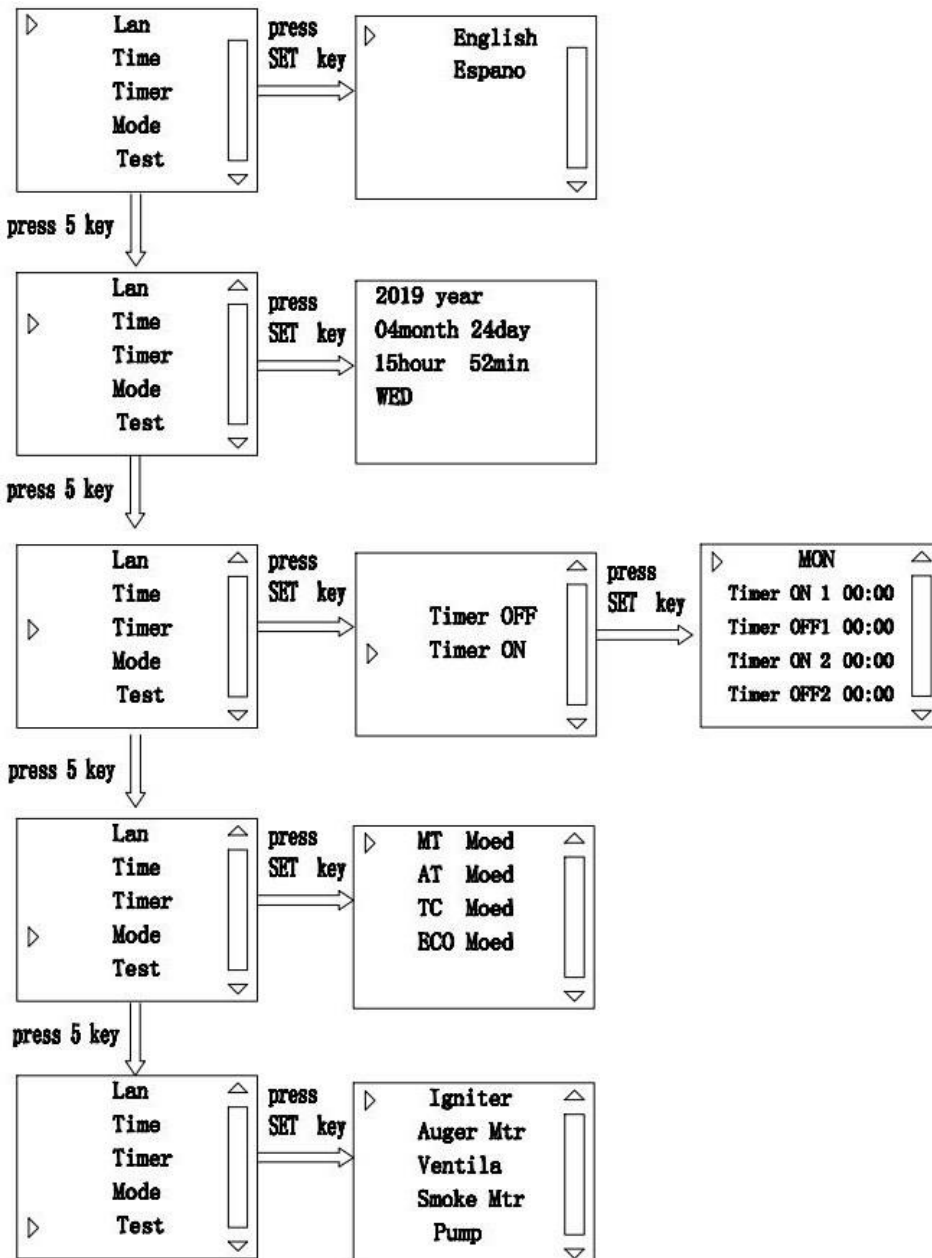

MT : operated by hand, fire power unadjustable automatically in this mode

AT: stove functions according to temperature sensor, once reached preset temperature stoves works at lowest fire power

TC: means stove functions according to indoor temperature control switch (indoor temperature control switch self-section), once reached preset temperature stoves works at lowest fire power for 15 mintues,if the room temperature keeping on increasing the stove stops working. When temperature is 2°C lower than preset temperature, stove reignites.

ECO: means stove once not reached preset temperature stoves works at highest fire power,once reached preset temperature stoves works at lowest fire power for 15 mintue if the room temperature keeping on increasing the stove stops working. When temperature

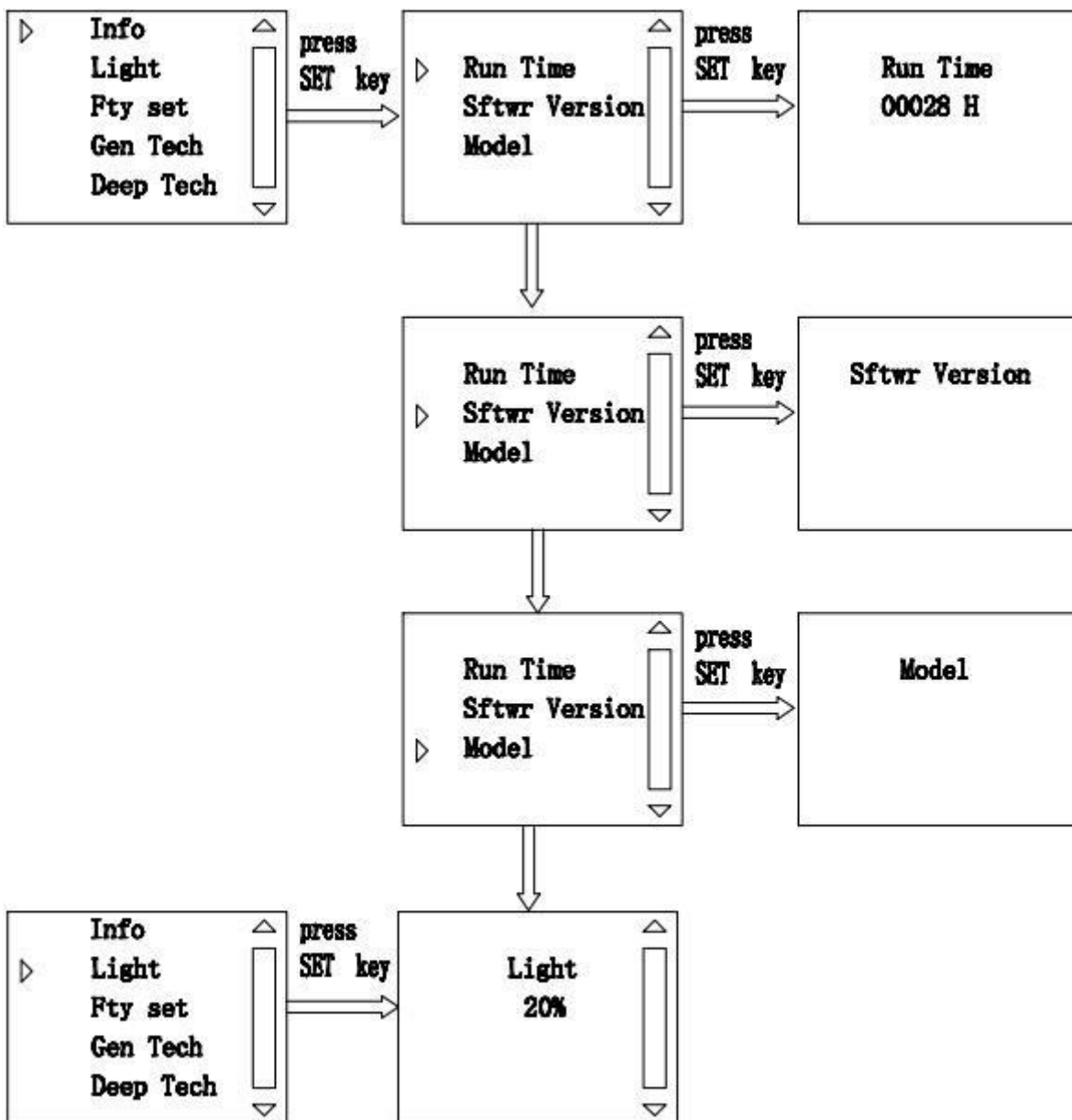

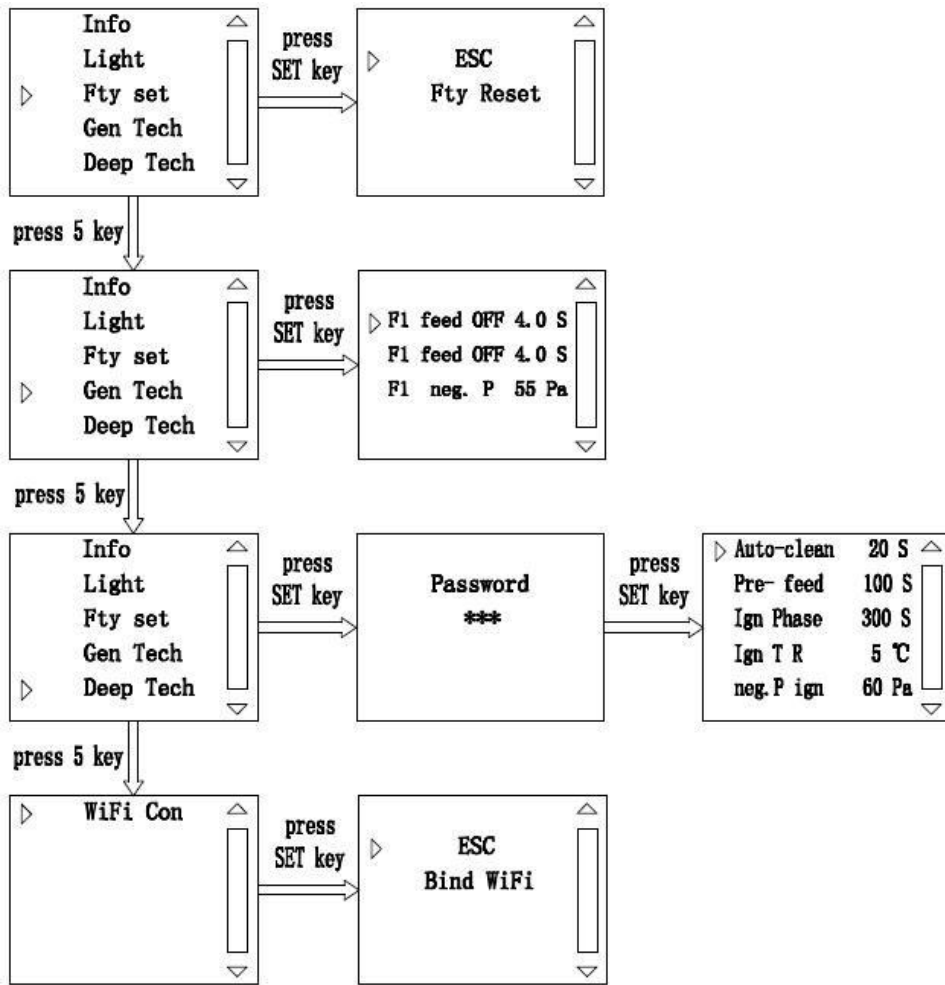

LANGUAGE: Two options including Chinese and English

TIME: Appears in sequence as year, month, date, hour, minute, weekday

WEEK TIMER: It means stove automatically turns on TIME ON1 at 0:00 , turns off TIME OFF1 at 00:00, then turns on TIME ON2 at 0:00TIME OFF2 at 00:00.

SELF-CHECK: In standby state, you can check whether the ignite, auger motor, convection blower,Exhaust motor is electrified properly.

INFORMATION: Check the total running time, program VERSION, and fireplace model.

LIGHT: Display Backlight Brightness

FACTORY SET: Restore factory defaults. (if you need modifyment please contact with professional staff before modifying)





GEN TECHNICAL: This allows to set work period and stop period of auger motor and speed of exhaust motor at every fire power level while stove working. (if you need modifyment please contact with professional staff before modifying)

DEEP TECHNICAL: This allows to set work period and stop period of auger motor and speed of exhaust motor at each igniting phase, set the temperature for defining igniting success. (if you need modifyment please contact with professional staff before modifying)

WIFI CONNECTION: WIFI wireless module selection, specific operation instructions see the APP operation instructions.



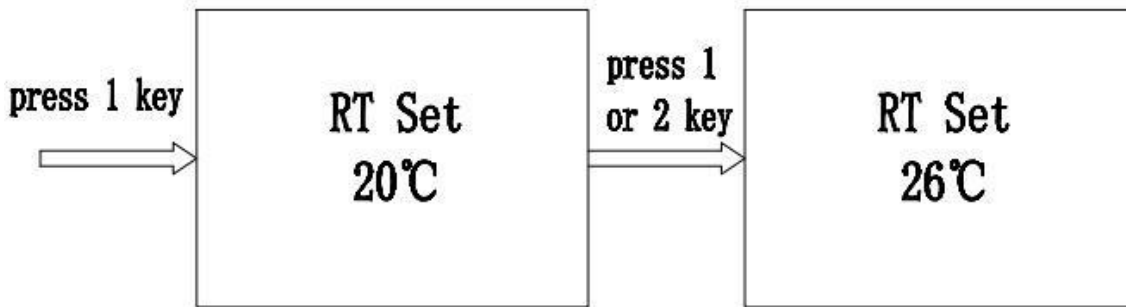

6.4 Temperature set:

6.4.1 Set room temperature:

Power on, press ¹ key, set the temperature as you want, press ₁ or ₂ can increase or decrease, press ₄ key to exit.



6.4.2 Set fire power level:



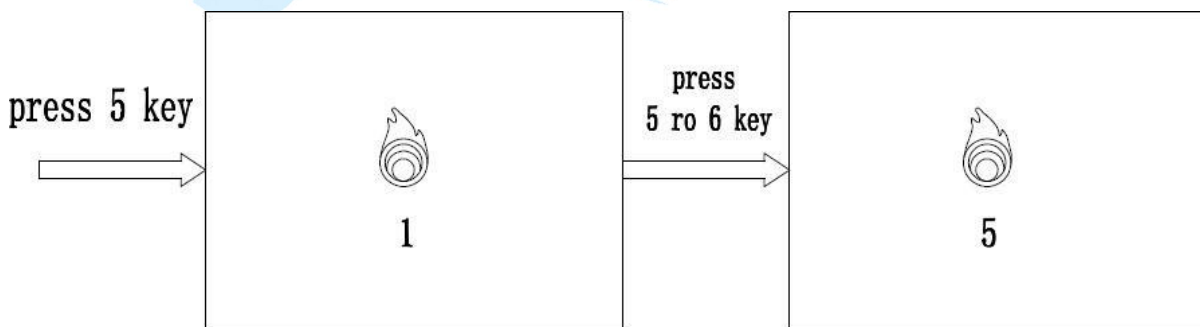

Press ₆ to enter into mode of fire power set, 5 fire power levels, ranging from 1st level to 5th level, 1st level is the weakest level while 5th level is the strongest level. 1 frame on display is 1st level, 2 frame on display is the 2nd level, etc. Press ₆ or ₅ to adjust then press ₄ to confirm and exit.



Parameters have been configured in factory, normally it doesn't need any adjustment. In adjustment because of pellet calorific value difference, please avoid too much pellet load, it will cause too strong fire, thus wasting the pellet and shortening the service life of stoves. This is the way to check whether the fire is too strong: during normal operation, press  to check temperature of exhaust, it should be less than value rated by factory, $\leq 200^{\circ}\text{C}$. If exhaust temperature is too high, it means the fire is too strong, please reduce pellet load quantity properly in the present fire power level.

Flue T	166.5°C
Chamber P	83 Pa
Flue N P	65 %

6.4.3 Set convection motor speed:

Press  to enter into mode of convection motor(ventilator) speed set, 5 speed levels, ranging from 1st level to 5th level, 1st level is the weakest level while 5th level is the strongest level. 1 frame on display is 1st level, 2 frame on display is the 2 nd level, etc. Press  or  to adjust, then press  to confirm and exit.

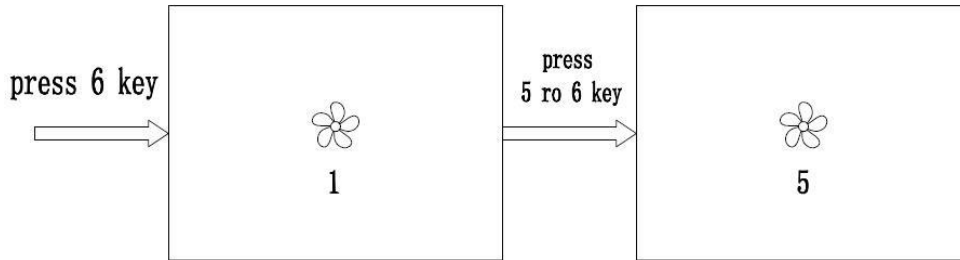

6.5 PARAMETERS SET:

(KM06 Example) GEN PARAMETERS

PARTS	power level1	power level 2	power level 3	power level 4	power level 5
Auger Motor	OFF: 4.5 S ON: 1.5 S	OFF: 4.5 S ON: 2.0 S	OFF: 4.0 S ON: 2.0 S	OFF: 3.8 S ON: 2.0 S	OFF: 3.5 S ON: 2.5 S
Exhaust Motor	43	44	44	45	46

Auger Motor:

The minimum scale is 0.1s, and the adjustment range of stop/open is 0-9.9s. For example, stop of first gear:4.5s, open of first gear:1.5s, which means stop of 4.0s, open of 1.5 and cycle.

Exhaust Motor:

The regulating range is 32% - 100% (72v-230v). The larger the value is, the greater the wind force will be, for example, the maximum wind force of regulating 100, the minimum wind force of regulating 32.

Note: This parameter is only for reference, because the different calorific value of pellet also need to change its parameters!

6.6 Overload fuse:

There is tube fuse in the power plug at the back of stove to avoid over voltage and over current. When the fuse burn out, please replace it with the same standard fuse.

Note: one spare fuse exist in the three-in-one switch.

7 Operating instruction of remote controller:



8 Installation of Stove:

- The stove must be installed on a suitable, solid, and horizontal floor;
- The minimum diameter of flue pipe is 80mm, and such a tube should be made of metal or other heat-resistant materials which can resist more than 220°C
- The joint of the flue pipe must be sealed because the stove can only work on basis of the differential pressure in stove and draft in the chimney to protect the system.
- Try to avoid bend connection from up direction to down direction. Horizontal pipes had better to upsweep about 3—5°, vertical pipes height≥3M, to create proper differential pressure, but the whole length of pipes shall be less than 8M.
- Exhaust pipes must be only used for this stove, no share use with other items.
- Flue pipes may be only made of heat-resistant and flame-retardant materials, such as silicon or mineral fiber materials;
- Don't locate the pipe outlet at closed region or semi-closed region, such as carport, garage, attic, low area and narrow corridor etc. these regions might gather exhaust. The pipe outlet must be at least 10M away from the flammable items.
- Decrease-diameter-installation is forbidden, there should be device that prevents smoke back and rain.
- The stove must be properly connected with flue pipe by your installer, and should also be approved by local firefighters;
- Note: The installation of the stove must be in compliance with the local regulations and rules.

8.1 Assembly of Flue pipe:

1. Measurement and mark for connection of flue pipes (take the floor protective plate as reference substance).
 2. Chisel Hole (the outlet may horizontally aligns to the stove's smoke vent, and 1.5m straight pipe may be placed outdoor; or the outlet may be vertically positioned 1.5 m higher from the stove's smoke vent, and the 1.5m straight pipe may be placed indoor).
 3. After the flue pipe is inserted into the wall and the gap should be filled and sealed with mineral fiber. The hole should be sealed with high- temperature resistant cement.
 4. Unless the cement is solidified, the chimney should not be connected with flue pipe.
- **The following is a standard installation drawing for your reference (1.5m straight pipe is placed indoor):**

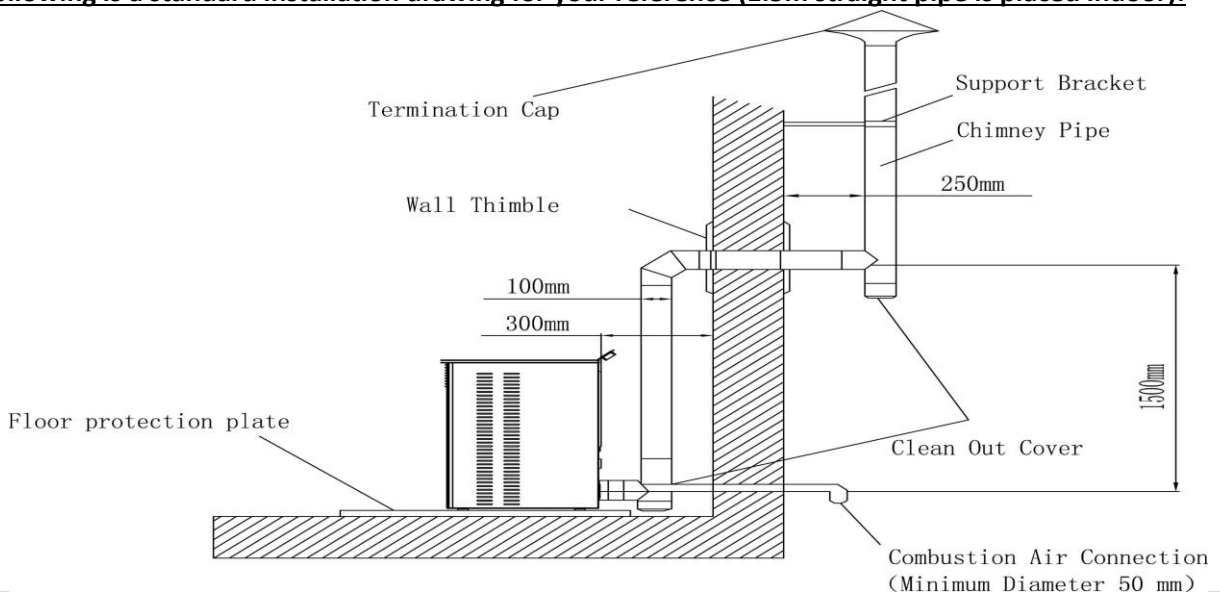

8.2 Floor Protection:

In case of a flammable flooring (such as wood or carpet floors), a fire-resistant protection mat is required, such as glass, steel, ceramic and so on.

Fire-resistant protection mat must be larger than the contacting area between the stove and floor. Front

wall: min.500mm

Each side wall: min.300mm

As shown below:

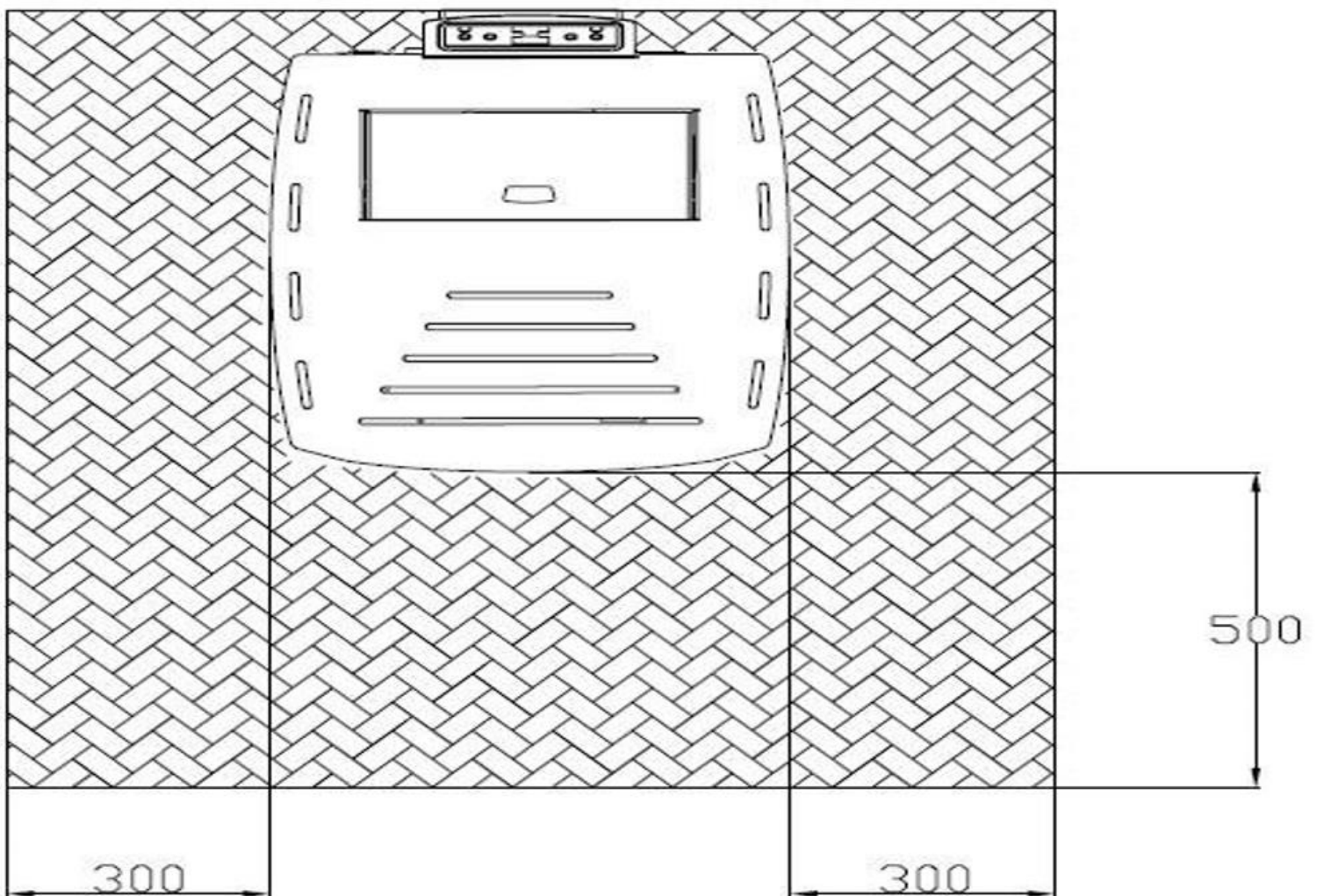

8.3 Surrounding Safe Distance:

- Corner: min. 250mm
- Back: min. 250mm
- Side: min. 350mm
- Front: min. 1000mm

As shown below:

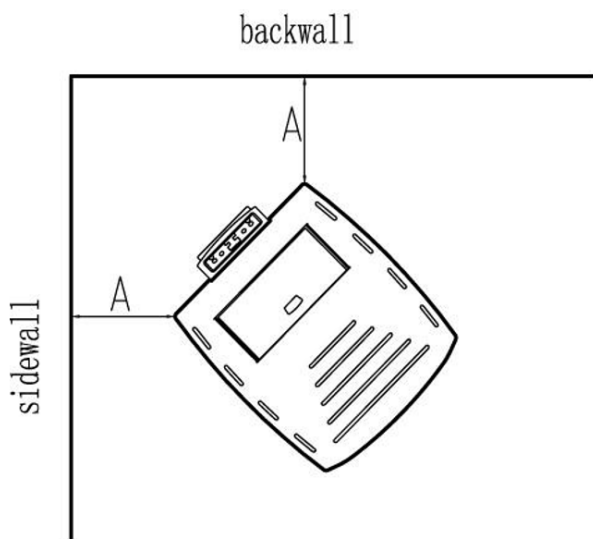

Corner Installation

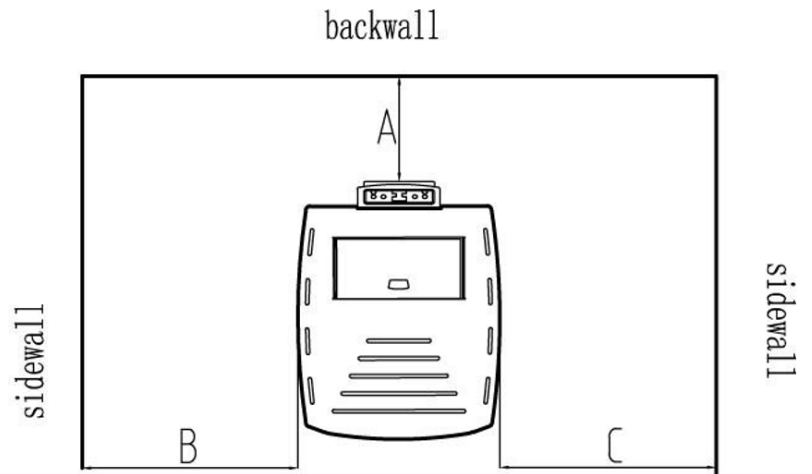

Parallel Installation

8.4 Power Supply:

European-style / three-hole socket/plug; 230V/50Hz

American-style / three-hole socket/plug; 110V / 60Hz

Normal power consumption: 80w

Ignition stage: 340W (about 5 minutes);

In order to avoid safety threats, the connecting cable must be kept away from heat or sharp parts; The socket must be reliably grounded.

8.5 Oxygen Supply for Combustor:

During burning process, the stove must draw air from the outside room. If not, please regularly open windows or doors for well ventilation, or install a proper air supply system.

9 General Steps and Instructions for operation:

9.1 General Notes:

The stove must be installed correctly

It is required to use high-quality pellets (pellet standard is DIN 51731, and OENORM M 7135, or similar). Pellet diameter: 6mm, length \leq 25mm.

Initial use phase, please try different brands pellets, then choose one brand that owns high calorific value but low ash content and low coking possibility. High-ash-content pellet will increase frequency of cleaning, and too-much-water pellet will block the auger thus causes inoperation of stoves. The product is neither suitable for burning wood, nor functions as an incinerator. It is strictly prohibited to put any waste, garbage, and a variety of plastics in the stove for burning. This is illegal, and the warranty terms and articles herein will be invalid if any above situation exists. If used the stove in accordance with the manual, overheating is not possible.

Improper operation against instructions may damage the electrical components (such as fans, auger motor, control unit, etc.) and reduce their working life.

9.2 Control Unit:

The stove is equipped with micro-processor and control components

All functions and setting can be realized through the operation panel mounted on top of the stove. Modifications to defaults should be approved by professional.

Incorrect use or settings may cause damage to the stove, and make the warranty terms and articles herein invalid.

9.3 Ignition Solution in case of auto-ignition failed:

In case of an auto-ignition failure, please remove all the pellets in the burner pot, and place the burner properly and restart the stove. Otherwise too much pellet in burner in igniting phase will cause detonatio Re-filling of wood pellets

Attention! Fire hazard!



Please keep pellets plastic bags far away from the stove while feeding pellets. Pellets should not be overflowed from the hopper cover; the overflowed pellets must be cleaned to avoid accidents. In order to prevent fire from extinguishing, make sure to keep the pellets in a proper filling level in the hopper. You can refill pellets if you can see the auger at the bottom of the hopper. The storage height of pellets should be checked regularly. Except for the feeding process, the hopper cover should be closed in any cases. **Attention!** To prevent high-temperature burns, please always wear protective gloves to open the hopper cover.

10 Cleaning and Maintenance

10.1 General:

Attention! Before doing any maintenance work, it is necessary to turn off the stove and wait till it's cooled down to room temperature, then pull the plug.

The cleaning interval depends on pellet quality and average heating power. Moist or high-ash & sawdust pellets may disrupt normal cleaning interval. Therefore, please always use high-quality pellets.

Maintenance schedule (Refer)

interval \ parts	1 day	2-3days	15days	30days	1 year
Burner pot	●				
Burner pot holder		●			
Ash box		●			
glass		●			
Fireplace flue				●	
Smoke pipe					●
Door Frame Sealing Strip					●
Remote Controller Battery					●

10.2 Ash cleanup:

10.2.1 Cleaning of Burner:

Check the burner pot regularly before use. Make sure the air duct is free from ash, soot or slag. The burner pot should be correctly placed in the chamber.

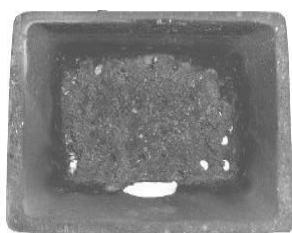

Example of dirty grate



Example of clean grate

10.2.2 Cleaning of burner pot base:

Every time when clean burner pot, please check the base under it if there is too much ash, if too much ash exist will decrease oxygen quantity in chamber thus cause bad combustion. Please clean the base with metal vacuum cleaner.



Example of dirty base



Example of clean base

Attention! Only when it is cooled to room temperature, and there is no flying ember, the vacuum cleaner can be used for cleaning ashes.

10.2.3 Cleaning of ash box:

Every 2 or 3 days please check ash in ash box and remove it. Only when ash is cooled to room temperature, and there is no flying ember, the vacuum cleaner can be used for cleaning ashes.



Example of dirty ash box



Example of clean ash box

10.3 Cleaning of the flue inside the fireplace

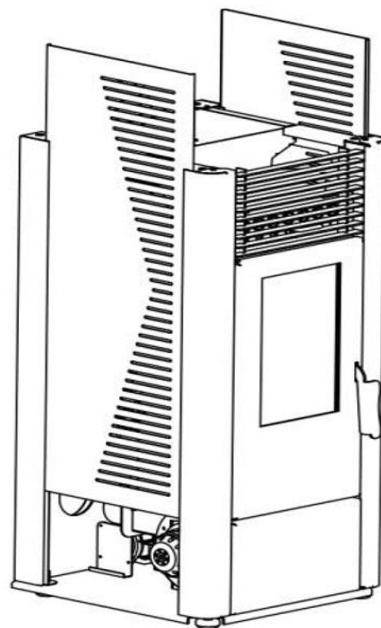
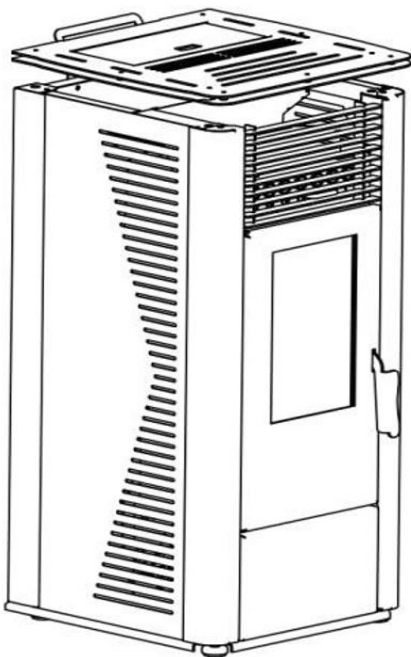

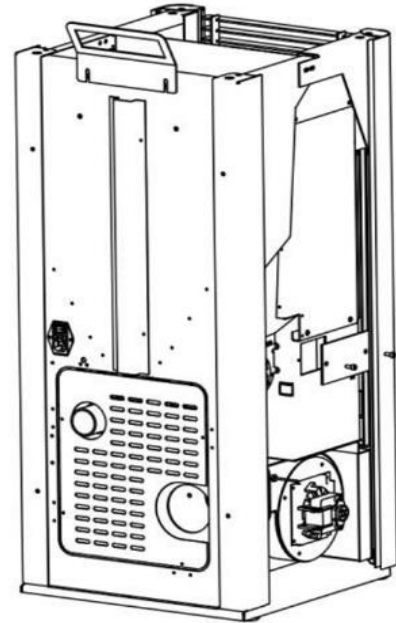
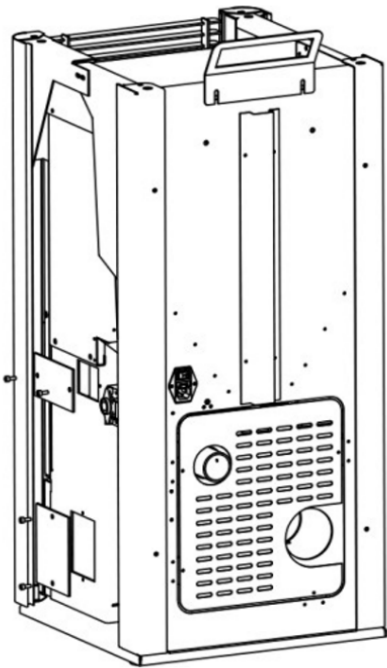

The flue tubes inside the stove are required to clean at least twice a year, or when about 500 kilograms of pellets have been burned out, or the stove has worked for more than 300 hours. Both ends of pipes should be cleaned.

10.3.1 The operation steps are performed as follows:

- Manually take the top cover upward to remove it.
- Disassemble the side panel.
- Take off 6 screws on plate cover of ash-clean open with hexagon socket key(4mm).
- Remove 3 plate cover and 3 gasket seal.
- Clean ashes from the flue tubes with a metal vacuum cleaner.
- After cleaning assemble in inverted order, pay attention to relocate the cover plates correctly and firmly sealed.

10.3.2 Clean the ash collector of exhaust chamber:

Ash collector of exhaust chamber is fixed on the rear bottom of the combustor

- Remove the back cover of stove;
- Remove the screws of two covers on exhaust device.
- Remove two covers.
- Sweep ashes inside with a vacuum cleaner.
- Please ensure the seal is firmed without leakage before reinstalling the cover.

10.4 Clean up the smoke blower:

In order to check and clean smoke blower, please unscrew the four hex head bolts of smoke blower, slowly remove the blower, use a vacuum cleaner to remove ashes in tubes or blower. Please ensure the seal is firmed without leakage before reinstalling.

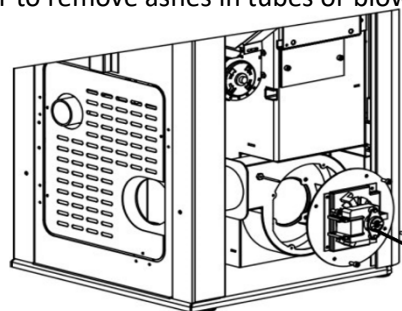

smoke blower

10.4.1 Cleaning of smoke pipes:

After the heating season, manually remove the T cover downward, make it clean and then relocate it, please be sure that it is relocated correctly and firmly sealed.



T cover



Example of dirty cover



Example of clean cover

10.5 Door Glass Cleaning:

The grime on the glass will change from black to brown, yellow and stone-gray because of the pellet quality and wood species. Wipe the grime with a damp cloth or windows eraser. Do not use caustic cleaning agents or hard metal brush to clean fouling, otherwise, the high-temperature resistant glass may be scratched or corroded.



Example of dirty glass



Example of clean glass

10.6 Hopper Cleaning:

In the period when the stove is out of use, you should remove all pellets from the hopper with a vacuum cleaner with a long extension. If the fuel is left in the hopper, it may get damp, stick together, and be difficult to light at the beginning of the next season

If the nozzle of the vacuum cleaner can not match with the grid on the hopper cover, please remove the grid to facilitate cleaning.

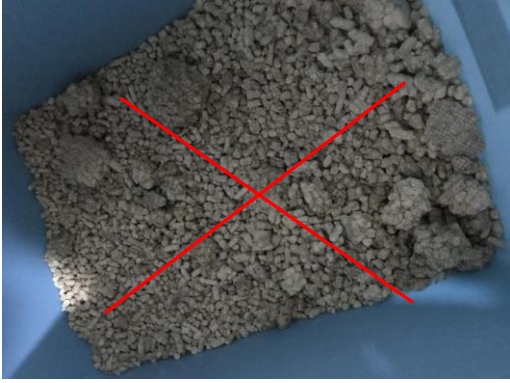

Caking poor quality pellet



Recommended good wood pellet

Attention: pull out the plug before cleaning.

10.7 Seal check

The seal ropes of door and glass should be checked at least once a year. Put a piece of paper between seal cord and surface of chamber, close the door, pull out the paper, if failed to pull it out it means sealed firmly. If the paper can be pull out it means the seal cord is damaged, please have them repaired or replaced.

11. Faults- Causes – Solution:

11.1 Errors and Solutions:

ALARM1:

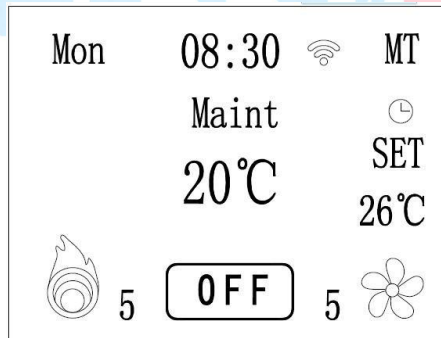

Cause: Maintenance time now, need to check the whole stove, to do some clean up, program checking and so on.

Solution: Enter into the interface of DEEP TECHNICAL, find maintenance time and make it twice of its original number. For example, if the original number is 30, after seeing ALARM MAINTENANCE please make it 60, in the future when you see this alarm again then make it 90, the rest can be done in the same way.

ALARM2:

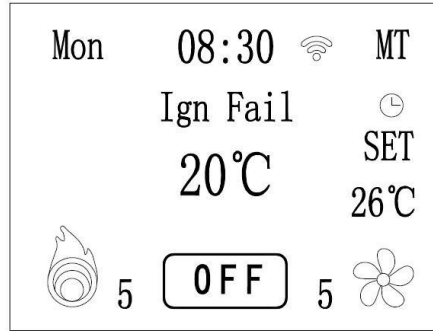

Cause: Ignition failure

- Solution:**
1. Check pellet exists or not in hopper, refill if not.
 2. Check slag-bonding exists or not in combustion bowl, please remove slag-bonding if it exists, and then relocate the bowl at right position.
 3. Ignition succeeding but alarms also, maybe pellet feeds too little, please adjust 4PB, 5PB to enlarge pellet feeding.

ALARM3:

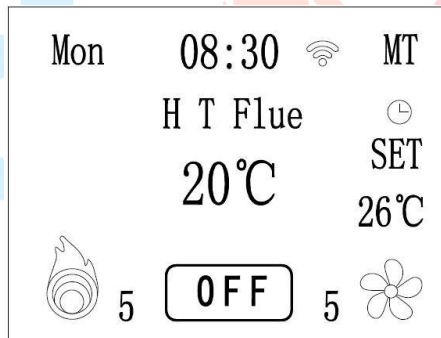

Cause: Over temperature of flue gas.

Solution: Decrease pellet feeding of auger motor in Chart 2.

ALARM4:

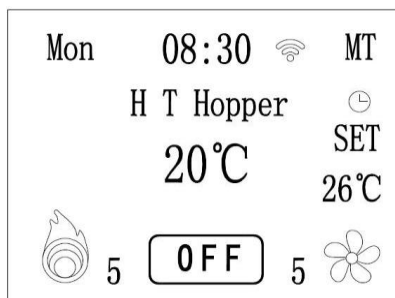

Cause: Over temperature in hopper.

- Solution:**
1. Decrease pellet feeding of auger motor in Chart
 2. Fault of switch of temperature control in hopper, replace with a new switch.

ALARM5:

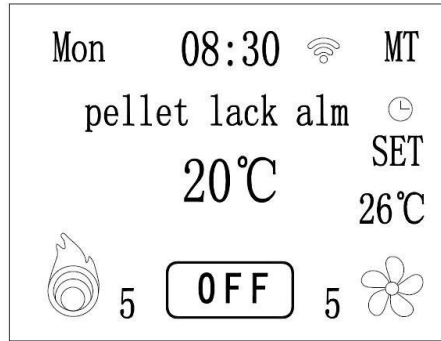

Cause: Hopper is empty.

Solution: Fill the hopper and re-start the stove.

ALARM6:

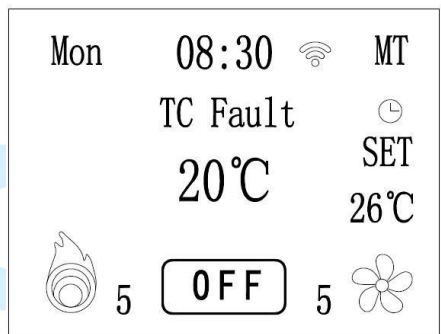

Cause: Thermocouple problem, wrong match with or poor contacting with anode and cathode.

Solution: 1.Check the contacting of the thermocuple.
2.Change the thermocuple.

ALARM7:

Cause: Pressure switch problem, or flue pipe with too low negative pressure.

Solution: 1.Re-check or change the pressure switch.
2. Re-check or change the exhaust motor.
3.Re-check and close the door.
4. Check and clean the flue pipes.

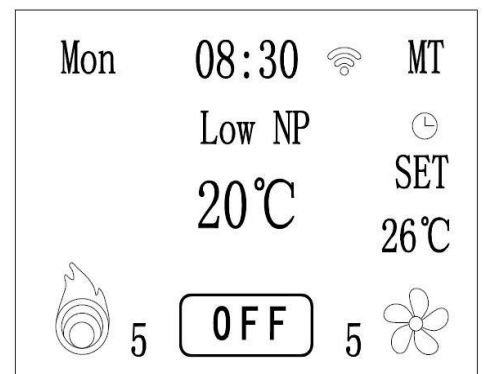

ALARM8:

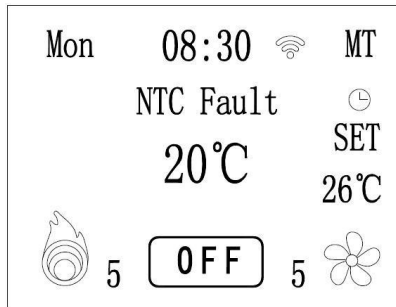

Cause: Temperature sensor problem or poor contacting.

- Solution:**
1. Check the contacting.
 2. Change the temperature sensor.

ALARM9:



Cause: Over temperature of flue gas.

- Solution:**
1. Decrease pellet feeding.
 2. Change the mandatory downgrade temperature (after contacting the distributor).

11.2 Causes and solutions for faults:

Item	Faults	Causes	Solutions	Remarks
1	Fire is burning weakly with orange flame; Front glass gradually turns black and burner pot is filling up with pellets	No enough air for combustion	<ol style="list-style-type: none"> 1. Burner pot must fit tightly in its holder. Check its fit.. 2. Clear ashes and slag to ensure smooth ventilation. If necessary, please replace with higher-quality pellets. 3. Check the air inlet duct and flue. And ensure they are empty and clean. 4. Check the chimney without too much soot. 5. Check the tightness of the stove door. 6. Check if Smoke blower is properly working 7. Have the stove checked and cleaned by your dealer or a certified technician. 	
2	The fire is extinguished, and the stove stops running.	<ol style="list-style-type: none"> 1. The hopper is empty; 2. Pellets can't be conveyed 3. The chamber temperature is too low; 4. The front door is not sealed or properly closed; 5. Pellet quality is not good enough; 6. No sufficient pellets are being fed. <p>The stove temperature is too high, and stove stops delivering pellets to the burner due to safe temperature limit (85°C temperature control).</p>	<ol style="list-style-type: none"> 1. Refill the hopper; 2. Check the Error 3: no pellets is being delivered; 3. Wait for one hour until the stove has been cooled down completely; 4. See the maintenance requirements herein; 5. Only use approved pellets; 6. Ask for professional to adjust your stove and use local pellets. 7. Manually restart the stove after the stove has been totally cooled down. 	
3	No pellets is being delivered;	<ol style="list-style-type: none"> 1. The hopper is empty; 2. Faulty PC board or auger motor ; 3. Auger feeding mechanism is blocked by screws or other objects. 4. Due to over-temperature, the auger has reached STL. (safe temperature limit) and stopped. 	<ol style="list-style-type: none"> 1. Check the hopper: refill it if necessary 2. Ask for professional to check the stove; if needed, please replace the faulty parts. 3. Clean the auger or hopper. 4. Manually restart the stove after the stove has been totally cooled down. 	



Item	Faults	Causes	Solutions	Remarks
4	The stove burns for a while, and then completely stops running.	<ol style="list-style-type: none"> The stove temperature does not reach the minimum limit. This may be caused by the temperature sensor. Replace it Defective wire connection of temperature sensor. Defective PC board. 	<ol style="list-style-type: none"> Clean the tubes and vents, and then ignite again. Ask for professional to replace the temperature sensor and check the PC board. Check wires for the temperature sensor are properly connected. 	
5	The stove does not start	<ol style="list-style-type: none"> No power supply. 	<ol style="list-style-type: none"> Please check the power connection, if the grid provides sufficient voltage. Check the safety fuse behind the hopper. 	
6	Ashes can be seen at outside of the stove.	<ol style="list-style-type: none"> The front door is open; The exhaust system is not sealed. 	<ol style="list-style-type: none"> Only open front door when stove is not in use. During operation, always keeps door closed. Seal any leakage of the exhaust device, with high temperature resistant AL strip, sealing rope, and heat resistant silicon materials. <p>Note: only check PC board and wire when stove is being unplugged. Repaired by professional only.</p>	
7	Abnormal noise	<ol style="list-style-type: none"> Auger motor noise; Blower noise; Exhaust blower noise; 	<ol style="list-style-type: none"> Check whether the auger motor runs properly. Check the blower is working properly. If necessary, replace the high-temperature resistant damping cushion at the end of the blower; Check the exhaust blower is working properly. 	<p>The normal noise of the stove during running is about 52dB (A) because the motors keep on running.</p>

12. Wiring Diagram:

